

O-Ringed End Plug Kit

59947-21K

- 4 Small End Plugs 9mm
- 1 Large End Plug 11mm
- 6 Small O-Rings
- 2 Large O-Rings

Note: Also fits AW55-51SN, AF 23/33 and RE5F22A units.

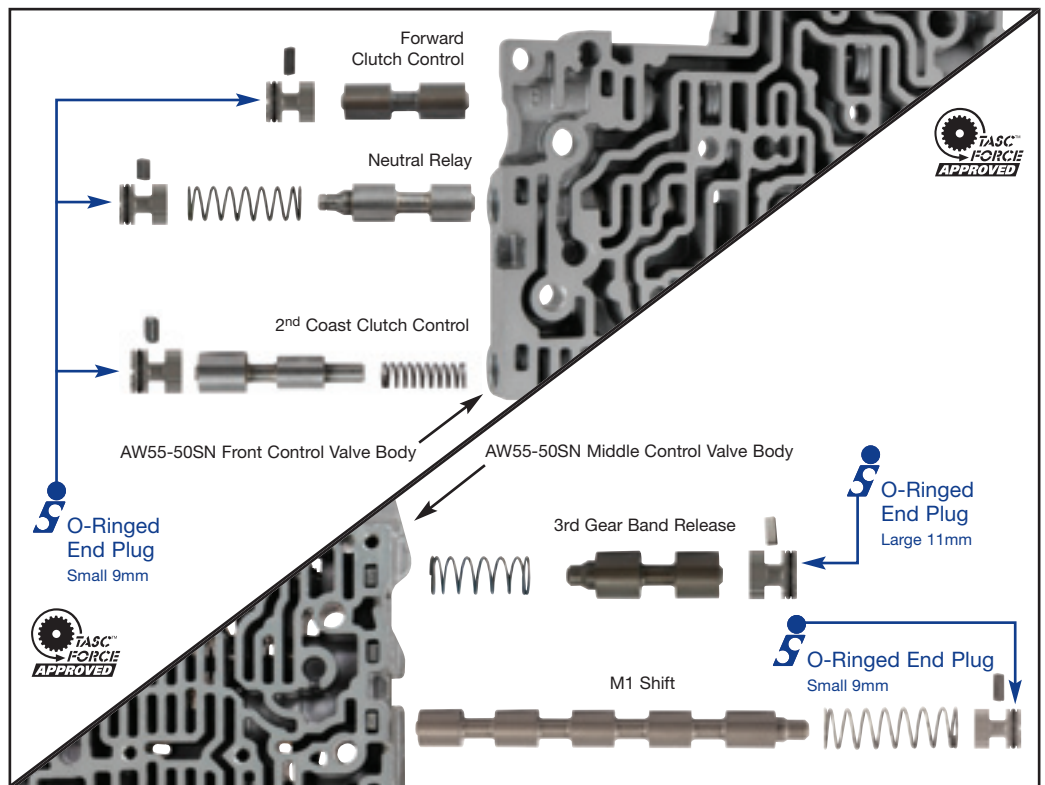

Disassembly Steps:

Remove and discard the OEM end plugs. Keep the OEM plug retainer for re-use with the new end plug.

Installation/Assembly Steps:

1. For both the 9mm and 11mm end plugs, install the correct o-ring into the shallow groove that is closer to one end of the plug (see Figure 1). The deeper centered groove is for the retainer. The ID small o-ring installs onto the 9mm end plug while the ID large o-ring fits onto the 11mm end plug.
2. Inspect the bottom of the “cast-in” chamfer at each bore that will receive an o-ringed end plug. Most valve bodies will have a small ridge at the entry of the valve bore. The ridge is difficult to see with the naked eye but can be located by carefully dragging a sharp “pick” down the chamfer (see Figure 2).

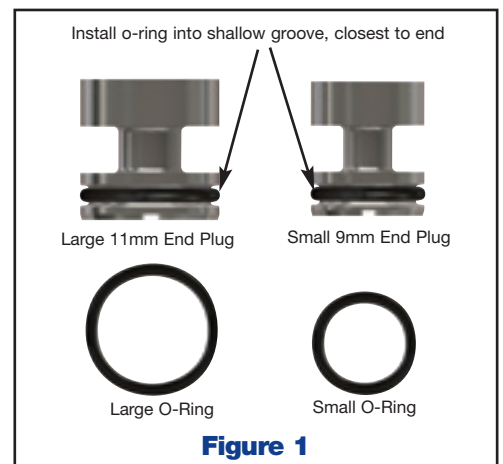

Figure 1

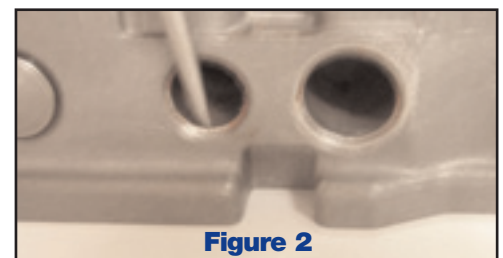

Figure 2

3. Remove the ridges identified in step 2. The recommended method is to use a 3/8" diameter flap wheel chucked in a miniature die grinder. Any method that removes the ridge without damaging the bore is acceptable. Remove the ridge and smooth the transition from the chamfer into the bore. If the ridge is not eliminated it will destroy the o-ring. In the case of the 3rd Gear Band (B4) Release Valve, it is necessary to form a small chamfer (approximately .020" to .030" deep) along the contoured edge of the valve bore (see Figure 3).
4. Thoroughly clean the valve body prior to assembly.
5. Install the appropriate valve train into the valve body bore.
6. Use a small amount of O-LUBE™, Trans-lube™, or new ATF to lubricate the o-ring, end plug and valve body chamfer. O-LUBE™ is the recommended lubricant.
7. Start the end plug into the bore with the o-ring outboard. In all the bores, the o-ring seals on the first land just inside the bore opening.
 - Use a small flat bladed screwdriver, inserted through the retainer post cavity, to control the movement of the end plug as the o-ring compresses into the bore.
 - Do not allow the o-ring to travel beyond the first segment of the bore, as the o-ring will be destroyed by the sharp edges of the intersecting retaining post cavity.
 - Use a brass or wood drift to press the end-plug into the bore. Use a hammer on the back of the drift and tap repeatedly to ease the o-ring into the bore. Do not seat the end-plug with one mighty whack or damage will occur to the o-ring.
8. Install the retainer post.

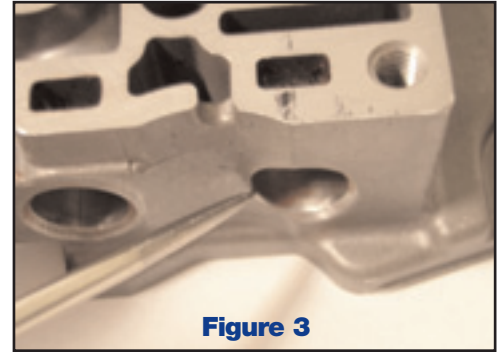

Figure 3

O-Ringed End-Plugs for AW55-50SN & AF33-5

	Valve	Location	Diameter
Included In Kit 59947-21K	Forward Clutch Control	Front Control VB	9mm
	2 nd Coast Clutch Control	Front Control VB	9mm
	Neutral Relay	Front Control VB	9mm
	M1 Shift	Middle Control VB	9mm
	3 rd Gear Band Release	Middle Control VB	11mm